



BOMBAY SUBURBAN ART AND CRAFT SOCIETY'S
L. S. RAHEJA SCHOOL OF ARCHITECTURE
(LACHMANDAS SEWARAM RAHEJA SCHOOL OF ARCHITECTURE)

B.VOC (INTERIOR DESIGN) APTITUDE TEST 2018 - 2019

(TO BE ENTERED BY STUDENT)								
SR.NO. - _____								
SUPERVISOR SIGN - _____								
EXAM SCORE TO BE ENTERED BY EXAMINER IN RED INK								
	SECTION A	SECTION B	SECTION C				TOTAL	
OUT OF	40 MARKS	60 MARKS	Q1 25 MARKS	Q2 25 MARKS	Q3 25 MARKS	Q4 25 MARKS	200	MARKS IN WORDS
MARKS SCORED								
EXAMINER'S SIGN								
MODERATORS SCORE TO BE ENTERED IN GREEN INK								
OUT OF	40 MARKS	60 MARKS	Q1 25 MARKS	Q2 25 MARKS	Q3 25 MARKS	Q4 25 MARKS	200	MODERATOR'S SIGN
MARKS SCORED								
QUALITY CHECK IN BLUE INK								SIGN OF QC



Instructions to examinees

1. The examination is of 3 hours duration. There are a total of 39 questions carrying a total of 200 marks. The entire paper is divided into three sections, A , B and C. All sections are compulsory.
2. There is no NEGATIVE marking for any section.
3. **Section A (40 marks)** contains a total of **20 multiple choice questions (MCQ)**. Each correct answer is awarded **2 marks**.
4. **Section B (60 marks)** contains a total of **15 multiple choice questions (MCQ)**. Each correct answer is awarded **4 marks**.
5. For these MCQ type questions, the answer is to be marked by filling circle **ONLY** corresponding to selected answer.
6. **Section C (100 marks)** contains a total of **04 Drawing based questions**.
Sketch is to be drawn in the space provided on answer booklet.
Marks will be awarded on basis of observation, visualization and design sensitivity.
7. Calculators, charts, graph sheets, tables, cellular phone or other electronic gadgets are NOT allowed in the examination hall.
8. Rough work is to be done last page marked for same.
9. If before, during, after the examination, it is found that a candidate is or has been guilty of misbehaviour or misconduct including breach of any of the rules laid down for the proper conduct of examination or candidate has been found to have copied or attempted to copy or used or attempted to use unfair means and is reported by Controller of Examinations, Officer in-charge, Invigilators or Examiner shall be liable to be instantly expelled or debarred from the examinations Action will be taken against the candidate according to the provide of rule.
10. When a candidate is to be expelled from the examination for copying or for any other offence by the officer in-charge, the candidate will have to give under his Signature a statement. If he refuses to give any statement, action may be taken without any reference to him again.
11. Before commencement of Examination, examine the answer book for loose sheets, incorrect size etc. & If found so, bring to the notice of the Supervisor and get it changed before writing.
12. Enter your examination Seat Number & all other particulars indicated on this cover before you start writing your answer. Do not write anything in the column reserved for marks.
13. Do not write your name or draw any kind of symbolic representation in any part of your answer books.
14. You must give up all answer-books supplied to you whether written in or blanks, before leaving the examination hall.
15. You will not be permitted to leave the examination, at the second bell, you must stop writing and be ready to hand over your answer-books to the supervisor. You must not leave your seat until all the answer-books are collected by the Supervisor.
16. If you want anything, ask your Supervisor, but do not leave your seat on any account.
17. Exchange of writing materials, stencils, mathematical instruments, etc. is strictly prohibited.
18. Smoking is strictly prohibited in examination hall.
19. THIS MANUSCRIPT CONTAIN **16** NUMBER OF SIDES



SECTION A (40 MARKS)

This section has 20 questions. Each question carries 2 marks, mark the correct answer by filling circle or by ticking on circle.

Q1	INTEL the world renowned company manufactures:		
<input type="radio"/>	Cellular Phones	<input type="radio"/>	Pagers
<input type="radio"/>	Microprocessor Chips	<input type="radio"/>	Video Cameras

Q2	The Texture of the sanitary wares is:		
<input type="radio"/>	Rough	<input type="radio"/>	Smooth
<input type="radio"/>	Undulating	<input type="radio"/>	White

Q3	How many spokes does the Chakra in the Indian National Flag contain?		
<input type="radio"/>	22	<input type="radio"/>	23
<input type="radio"/>	24	<input type="radio"/>	25

Q4	Martyr's Day is celebrated on:		
<input type="radio"/>	30 th January	<input type="radio"/>	2 nd October
<input type="radio"/>	8 th December	<input type="radio"/>	5 th September

Q5	ATM stands for:		
<input type="radio"/>	Atlantic Treaty Machine	<input type="radio"/>	Any Time Money
<input type="radio"/>	Automated Teller Machine	<input type="radio"/>	Automatic Transfer Mechanism

Q6	"Deodhar Trophy" is associated with:		
<input type="radio"/>	Hockey	<input type="radio"/>	Football
<input type="radio"/>	Cricket	<input type="radio"/>	Kabaddi



Q7	Use of different colours to represent various elevational features of ground is known as:		
<input type="radio"/>	Contours	<input type="radio"/>	Sciography
<input type="radio"/>	Isobars	<input type="radio"/>	Layer Shading

Q8	The statue of blindfolded women with a balance in hand symbolizes:		
<input type="radio"/>	Peace	<input type="radio"/>	Freedom
<input type="radio"/>	Liberty	<input type="radio"/>	Justice

Q9	The colour listed below is not primary colour:		
<input type="radio"/>	Yellow	<input type="radio"/>	Orange
<input type="radio"/>	Red	<input type="radio"/>	Blue

Q10	Myanmar is new name of which country?		
<input type="radio"/>	Burma	<input type="radio"/>	Sumatra
<input type="radio"/>	Bangladesh	<input type="radio"/>	Borneo

Q11	Bull's Eye is the term associated with:		
<input type="radio"/>	Shooting	<input type="radio"/>	Bull Fight
<input type="radio"/>	Swimming	<input type="radio"/>	Wrestling



Q12	Which country is known as "The Land of Rising Sun"?		
<input type="radio"/>	North Korea	<input type="radio"/>	South Korea
<input type="radio"/>	China	<input type="radio"/>	Japan

Q13	Guilt : Past :: Hope : ?		
<input type="radio"/>	Despair	<input type="radio"/>	Present
<input type="radio"/>	Future	<input type="radio"/>	Life

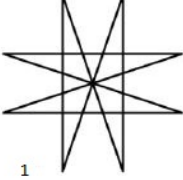

Q14	Flower : Bud :: Fruit: ?
<input type="radio"/> Seed	<input type="radio"/> Flower
<input type="radio"/> Petal	<input type="radio"/> Tree
Q15	Doctor : Medicine :: Teacher : ?
<input type="radio"/> Class	<input type="radio"/> College
<input type="radio"/> Lecture	<input type="radio"/> Student
Q16	Beginning : End :: First : ?
<input type="radio"/> Second	<input type="radio"/> Last
<input type="radio"/> Beginner	<input type="radio"/> Pioneer
Q17	Symphony : Composer :: Fresco : ?
<input type="radio"/> Leonardo	<input type="radio"/> Michelangelo
<input type="radio"/> Fine Artist	<input type="radio"/> Painter
Q18	Food : Menu :: Library : ?
<input type="radio"/> Books	<input type="radio"/> Librarian
<input type="radio"/> Catalogue	<input type="radio"/> Shelf
Q19	Design : ? :: Rhythm : Music
<input type="radio"/> Building	<input type="radio"/> Architecture
<input type="radio"/> Beauty	<input type="radio"/> Symmetry
Q20	Suggest Antonym of NATIVE from following
<input type="radio"/> Foreigner	<input type="radio"/> Newcomer
<input type="radio"/> From the Land	<input type="radio"/> Alien

SECTION B (60 MARKS)

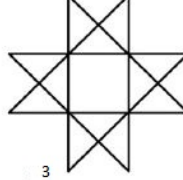
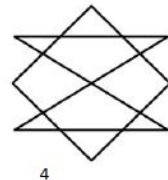
Q1	Identify which figures can be drawn without lifting pencil or retracting lines.			
				
<input type="radio"/>	Figures 1, 3, 4	<input type="radio"/>	All of above	
<input type="radio"/>	Figures 2,3,4	<input type="radio"/>	None of above	

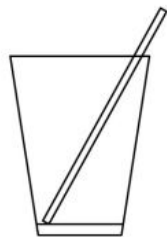
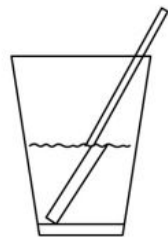
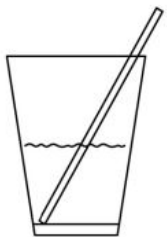
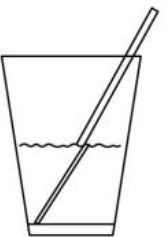
Q2	At left is an empty glass with straw in it, from the options given below, identifies the correct representation of the straw when the glass is filled with water.			
				
<input type="radio"/>	A	<input type="radio"/>	C	
<input type="radio"/>	B	<input type="radio"/>	D	

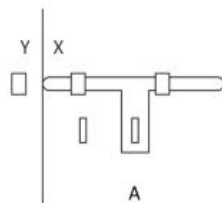
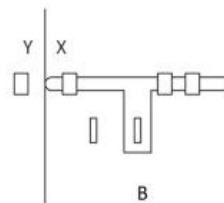
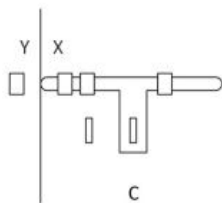
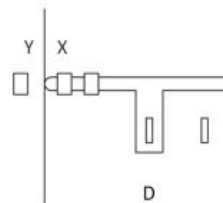
Q3	Shown below are schematic diagram of a regular door latch. X represents the door, and Y represents the frame in wall .Identify which latch can be used for correct locking of the door.			
				
<input type="radio"/>	A	<input type="radio"/>	C	
<input type="radio"/>	B	<input type="radio"/>	D	

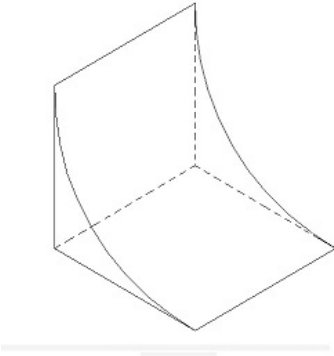
<p>Q4</p>		<p>A. Count total no. of Vertical Faces: _____</p> <p>B. Count total no. of Vertices: _____</p>
------------------	---	---

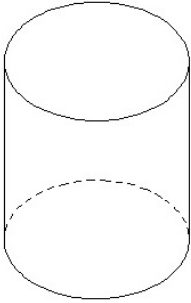
<p>Q5</p>		<p>A. Count no. of Curve surfaces: _____</p> <p>B. Count the no. of Edges: _____</p>
------------------	--	--

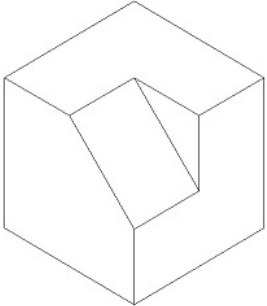
<p>Q6</p>		<p>A. Count total no. of surfaces: _____</p> <p>B. Count total no. of Edges: _____</p>
------------------	---	--

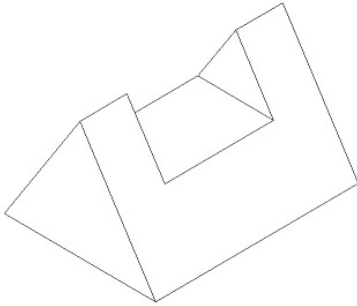
<p>Q7</p>		<p>A. Count total no. of slant surfaces: _____</p> <p>B. Count total no. of Vertices: _____</p>
------------------	---	---

8.

Draw how the Object looks from arrow side:

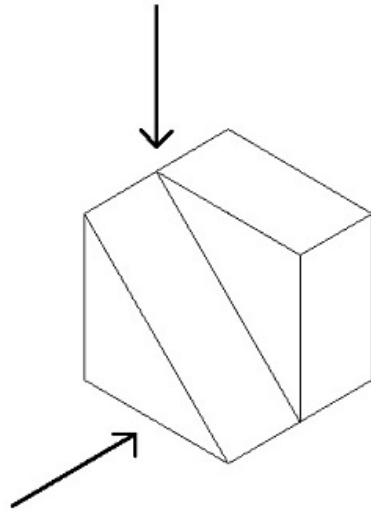

9.

Draw how the Object looks from arrow side:

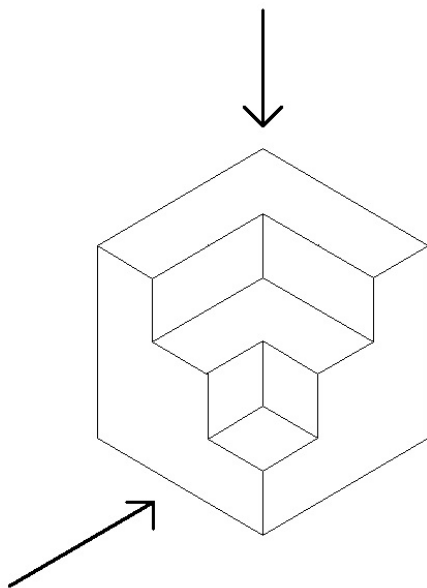

10.



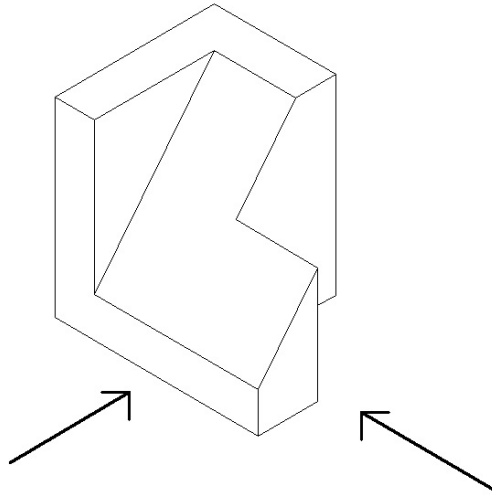

Draw how the Object looks from arrow side

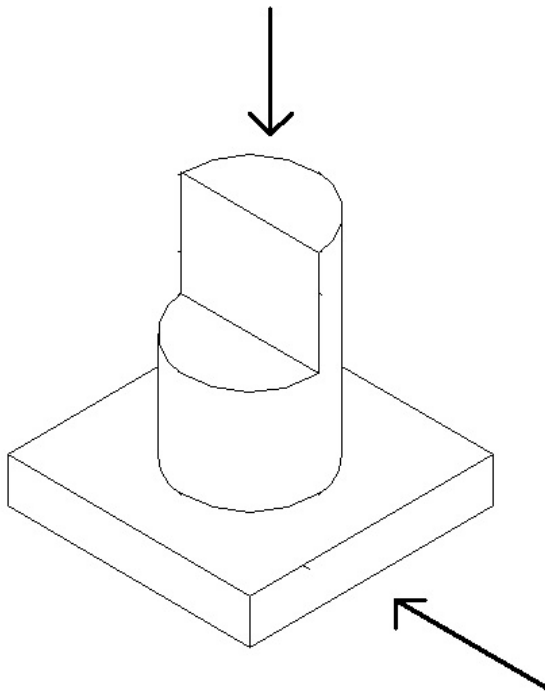

11.

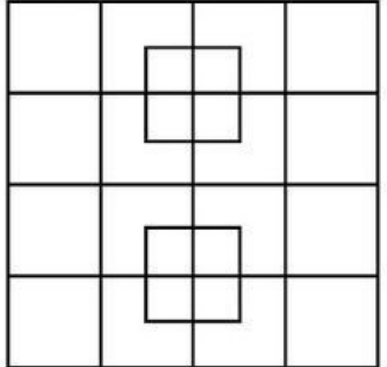
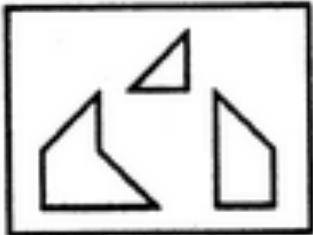
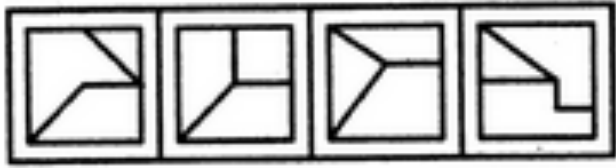
Draw how the Object looks from arrow side

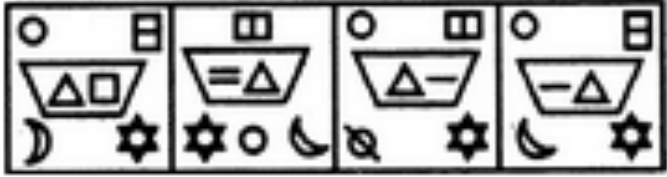

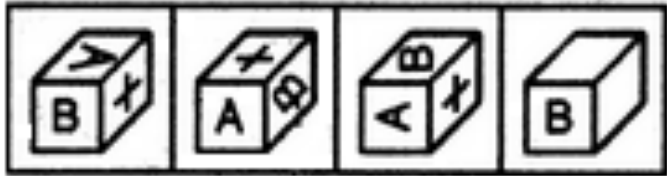
12.	Count the number of square in square and select appropriate option		
			
<input type="radio"/> 44	<input type="radio"/> 38	<input type="radio"/> 41	<input type="radio"/> 40
13.	Find out which of the figures (1), (2), (3) and (4) can be formed from the pieces given in figure (X).		
 			
<input type="radio"/> 1	<input type="radio"/> 2	<input type="radio"/> 3	<input type="radio"/> 4
14.	Select the alternative in which the specified components of the key figure (X) are found:		
 			
<input type="radio"/> 1	<input type="radio"/> 2	<input type="radio"/> 3	<input type="radio"/> 4
15.	Find out how the key figure (X) will look like after rotation.		
 			
<input type="radio"/> 1	<input type="radio"/> 2	<input type="radio"/> 3	<input type="radio"/> 4

SECTION C (100 MARKS)

This section has 4 questions. Each question carries 25 marks.

- Q. 1 Render the given piece of furniture in any medium:**
Evaluation: Neatness, Colour Selection, Textures

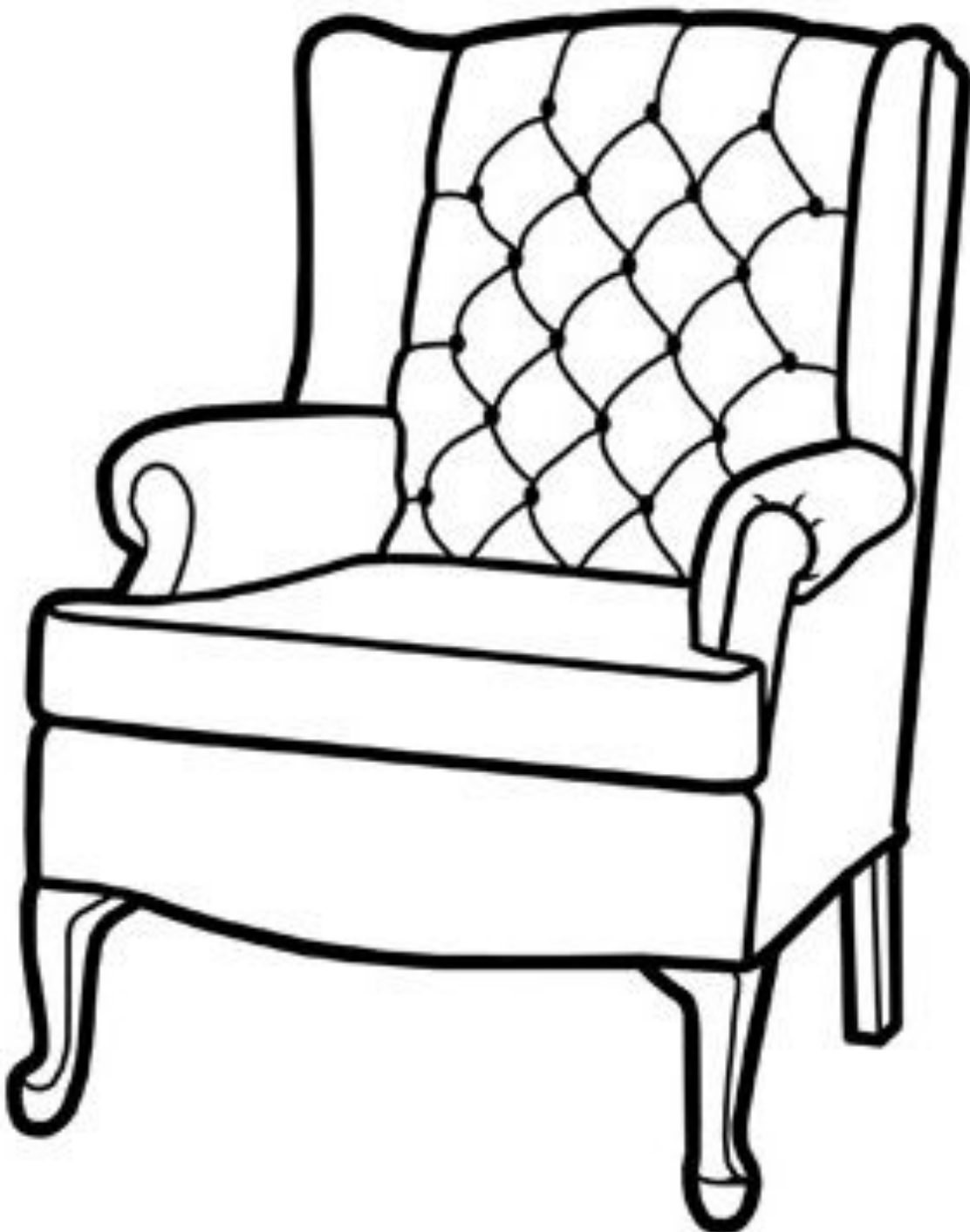

- Q. 2** Draw proportionate Centre Table, Side Table, Appropriate Lamps, Murals, Planters etc. In pencil only to decorate following Living Room

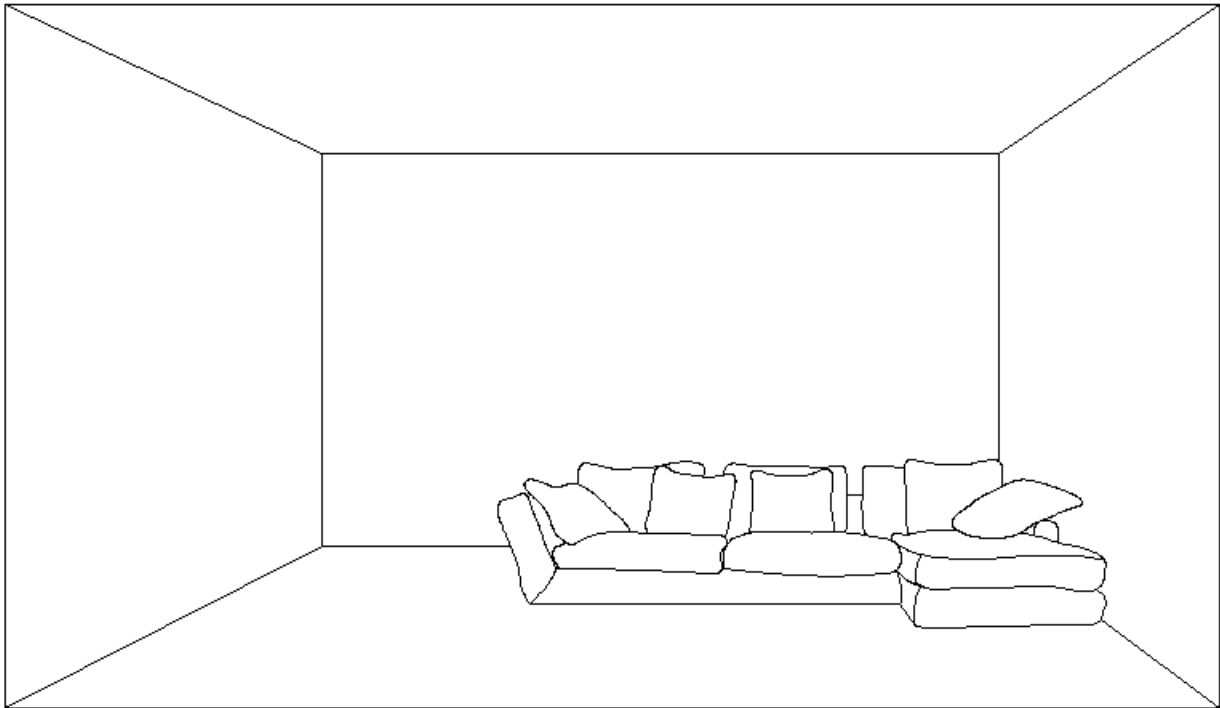

- Q 3.** Draw the shade and shadow of the given object. The Arrow shows the direction of Light

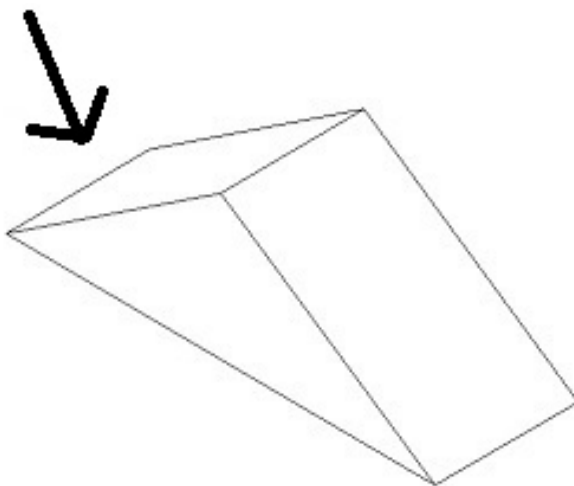



- Q. 4 Draw any Artistic composition, by using following elements given below :
Squares, Straight Lines and Curve Lines.
Do not colour the composition

A large, empty rectangular box with a thin black border, intended for the student to draw an artistic composition using squares, straight lines, and curve lines.



BOMBAY SUBURBAN ART AND CRAFT SOCIETY'S
L. S. RAHEJA SCHOOL OF ARCHITECTURE
(LACHMANDAS SEWARAM RAHEJA SCHOOL OF ARCHITECTURE)

B.VOC (INTERIOR DESIGN) APTITUDE TEST 2018 - 2019

ROUGH WORK SHEET



BOMBAY SUBURBAN ART AND CRAFT SOCIETY'S
L. S. RAHEJA SCHOOL OF ARCHITECTURE
(LACHMANDAS SEWARAM RAHEJA SCHOOL OF ARCHITECTURE)

B.VOC (INTERIOR DESIGN) APTITUDE TEST 2018 - 2019

ROUGH WORK SHEET



BOMBAY SUBURBAN ART AND CRAFT SOCIETY'S
L. S. RAHEJA SCHOOL OF ARCHITECTURE
(LACHMANDAS SEWARAM RAHEJA SCHOOL OF ARCHITECTURE)

B.VOC (INTERIOR DESIGN) APTITUDE TEST 2018 - 2019

ROUGH WORK SHEET