



BOMBAY SUBURBAN ART AND CRAFT SOCIETY'S
L. S. RAHEJA SCHOOL OF ARCHITECTURE
(LACHMANDAS SEWARAM RAHEJA SCHOOL OF ARCHITECTURE)

B.VOC (INTERIOR DESIGN) APTITUDE TEST 2019 - 2020

(TO BE ENTERED BY STUDENT)

SR.NO. - _____

SUPERVISOR SIGN - _____

EXAM SCORE TO BE ENTERED BY EXAMINER IN RED INK

	SECTION A	SECTION B	SECTION C				TOTAL	
OUT OF	40 MARKS	60 MARKS	Q1 25 MARKS	Q2 25 MARKS	Q3 25 MARKS	Q4 25 MARKS	200	MARKS IN WORDS
MARKS SCORED								
EXAMINERS SIGN								

MODERATORS SCORE TO BE ENTERED IN GREEN INK

OUT OF	40 MARKS	60 MARKS	Q1 25 MARKS	Q2 25 MARKS	Q3 25 MARKS	Q4 25 MARKS	200	MODERATOR'S SIGN
MARKS SCORED								
QUALITY CHECK IN BLUE INK								SIGN OF QC



Instructions to examinees

1. The examination is of 3 hours duration. There are a total of 39 questions carrying a total of 200 marks. The entire paper is divided into three sections, A , B and C. All sections are compulsory.
2. There is no NEGATIVE marking for any section.
3. **Section A (40 marks)** contains a total of **20 multiple choice questions (MCQ)**. Each correct answer is awarded **2 marks**.
4. **Section B (60 marks)** contains a total of **15 multiple choice questions (MCQ)**. Each correct answer is awarded **4 marks**.
5. For these MCQ type questions, the answer is to be marked by filling circle **ONLY** corresponding to selected answer.
6. **Section C (100 marks)** contains a total of **04 Drawing based questions**.
Sketch is to be drawn in the space provided on answer booklet.
Marks will be awarded on basis of observation, visualization and design sensitivity.
7. Calculators, charts, graph sheets, tables, cellular phone or other electronic gadgets are NOT allowed in the examination hall.
8. Rough work is to be done last page marked for same.
9. If before, during, after the examination, it is found that a candidate is or has been guilty of misbehaviour or misconduct including breach of any of the rules laid down for the proper conduct of examination or candidate has been found to have copied or attempted to copy or used or attempted to use unfair means and is reported by Controller of Examinations, Officer in-charge, Invigilators or Examiner shall be liable to be instantly expelled or debarred from the examinations Action will be taken against the candidate according to the provide of rule.
10. When a candidate is to be expelled from the examination for copying or for any other offence by the officer in-charge, the candidate will have to give under his Signature a statement. If he refuses to give any statement, action may be taken without any reference to him again.
11. Before commencement of Examination, examine the answer book for loose sheets, incorrect size etc. & If found so, bring to the notice of the Supervisor and get it changed before writing.
12. Enter your examination Seat Number & all other particulars indicated on this cover before you start writing your answer. Do not write anything in the column reserved for marks.
13. Do not write your name or draw any kind of symbolic representation in any part of your answer books.
14. You must give up all answer-books supplied to you whether written in or blanks, before leaving the examination hall.
15. You will not be permitted to leave the examination, at the second bell, you must stop writing and be ready to hand over your answer-books to the supervisor. You must not leave your seat until all the answer-books are collected by the Supervisor.
16. If you want anything, ask your Supervisor, but do not leave your seat on any account.
17. Exchange of writing materials, stencils, mathematical instruments, etc. is strictly prohibited.
18. Smoking is strictly prohibited in examination hall.
19. THIS MANUSCRIPT CONTAIN **16** NUMBER OF SIDES



SECTION A (40 MARKS)

This section has 20 questions. Each question carries 2 marks, mark the correct answer by filling circle or by ticking on circle.

Q1	LED stands for:		
<input type="radio"/>	Light Exiting Diodes	<input type="radio"/>	Light Emitting Diodes
<input type="radio"/>	Light Evaporating Distance	<input type="radio"/>	Live Electrical Destruction

Q2	The Texture of the Kitchen Platform is:		
<input type="radio"/>	Rough	<input type="radio"/>	Smooth
<input type="radio"/>	Undulating	<input type="radio"/>	White

Q3	Who wrote ' Vande Mataram '?		
<input type="radio"/>	Mahatma Gandhi	<input type="radio"/>	Ravindranath Tagore
<input type="radio"/>	Subhashchandra Bose	<input type="radio"/>	Bankimchandra Chatterji

Q4	Labour's Day is celebrated on:		
<input type="radio"/>	30 th June	<input type="radio"/>	2 nd October
<input type="radio"/>	6 th December	<input type="radio"/>	1 st May

Q5	WHO stands for:		
<input type="radio"/>	War Home Organization	<input type="radio"/>	Warm Homes for Orphans
<input type="radio"/>	World Health Organization	<input type="radio"/>	Ware Housing Organisation

Q6	"Thomas Cup" is associated with:		
<input type="radio"/>	Hockey	<input type="radio"/>	Football
<input type="radio"/>	Cricket	<input type="radio"/>	Badminton



Q7	Any Interior Layout Plan is in :		
<input type="radio"/>	Single dimension	<input type="radio"/>	Two dimension
<input type="radio"/>	Third dimension	<input type="radio"/>	Fourth Dimension

Q8	The tallest statue of Sardar Patel is on the banks of the following river		
<input type="radio"/>	Sabarmati	<input type="radio"/>	Narmada
<input type="radio"/>	Taapi	<input type="radio"/>	Godavari

Q9	The colour listed below is not a warm colour:		
<input type="radio"/>	Yellow	<input type="radio"/>	Orange
<input type="radio"/>	Red	<input type="radio"/>	Blue

Q10	Holland is also known as ?		
<input type="radio"/>	Poland	<input type="radio"/>	Iceland
<input type="radio"/>	Amsterdam	<input type="radio"/>	Netherlands

Q11	' Smash' is the term associated with following sport:		
<input type="radio"/>	Kabaddi	<input type="radio"/>	Badminton
<input type="radio"/>	Cricket	<input type="radio"/>	Hockey

Q12	In which country, you see : "The Northern Lights"?		
<input type="radio"/>	Northern Ireland	<input type="radio"/>	North Korea
<input type="radio"/>	Norway	<input type="radio"/>	Sweden

Q13	Zakir Hussain : Tabla :: Ravi Shankar : ?		
<input type="radio"/>	Flute	<input type="radio"/>	Sarod
<input type="radio"/>	Sitar	<input type="radio"/>	Santoor



Q14 Parrot : Bird :: Duck: ?	
<input type="radio"/> Bird	<input type="radio"/> Animal
<input type="radio"/> Mammal	<input type="radio"/> Aquatic

Q15 Hospital : Medicine :: Teacher : ?	
<input type="radio"/> Class	<input type="radio"/> College
<input type="radio"/> Lecture	<input type="radio"/> Student

Q16 Maharashtra : Mumbai :: Assam : ?	
<input type="radio"/> Gauhati	<input type="radio"/> Shillong
<input type="radio"/> Gangtok	<input type="radio"/> Dispur

Q17 Symphony : Composer :: Last Supper painting : ?	
<input type="radio"/> Leonardo	<input type="radio"/> Michelangelo
<input type="radio"/> Van Gogh	<input type="radio"/> Raphael

Q18 Tajmahal : Agra :: Big Ben : ?	
<input type="radio"/> Paris	<input type="radio"/> England
<input type="radio"/> London	<input type="radio"/> Rome

Q19 Bird : Peacock :: Animal : ?	
<input type="radio"/> Lion	<input type="radio"/> Elephant
<input type="radio"/> Cow	<input type="radio"/> Tiger

Q20 Gulzar is not a	
<input type="radio"/> Director	<input type="radio"/> Lyricist
<input type="radio"/> Writer	<input type="radio"/> Cinematographer





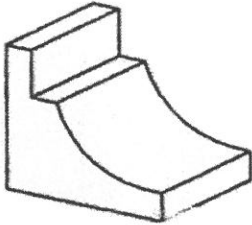

SECTION B (60 MARKS)

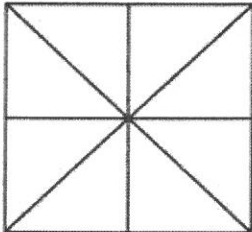
This section has 15 questions. Each question carries 4 marks, mark the correct answer by filling circle or by ticking on circle.

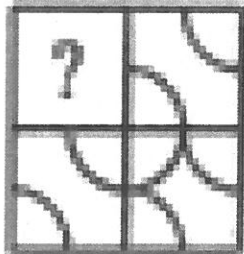
Q1	Count the total number of surfaces shown in the object below.	
		
<input type="radio"/> 10	<input type="radio"/> 8	
<input type="radio"/> 9	<input type="radio"/> 12	

Q2	Count the total number of triangles shown in the object below.	
		
<input type="radio"/> 16	<input type="radio"/> 18	
<input type="radio"/> 12	<input type="radio"/> 14	

Q3	Identify the figure which would complete the pattern of the figure.	
		
<input type="radio"/> 	<input type="radio"/> 	
<input type="radio"/> 	<input type="radio"/> 	

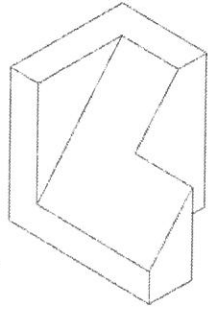
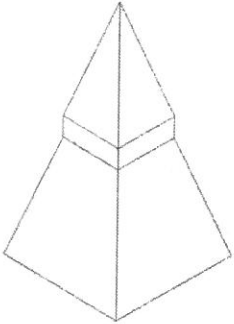
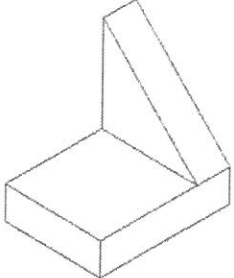
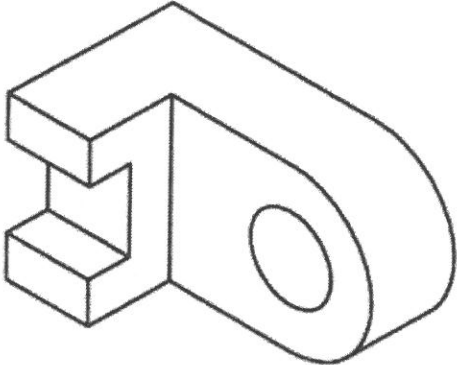

Q4		A. Count total no. of Vertical Faces: _____ B. Count total no. of Vertices: _____
Q5		A. Count total no. of slant surfaces: _____ B. Count total no. of Edges: _____
Q6		A. Count total no. of surfaces: _____ B. Count total no. of Edges: _____
Q7		A. Count total no. of surfaces: _____ B. Count total no. of Edges: _____

Q8.

DRAW HOW THE OBJECT LOOKS FROM THE ARROW SIDE

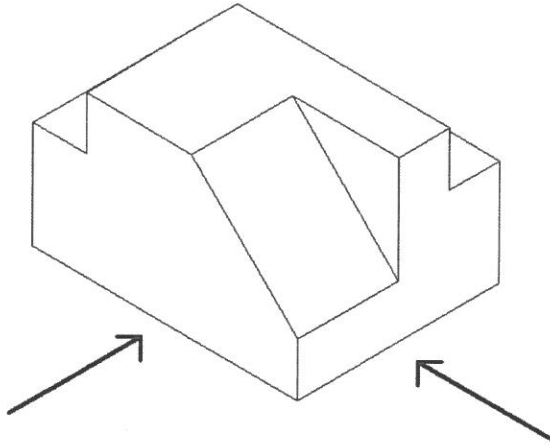

Q9.

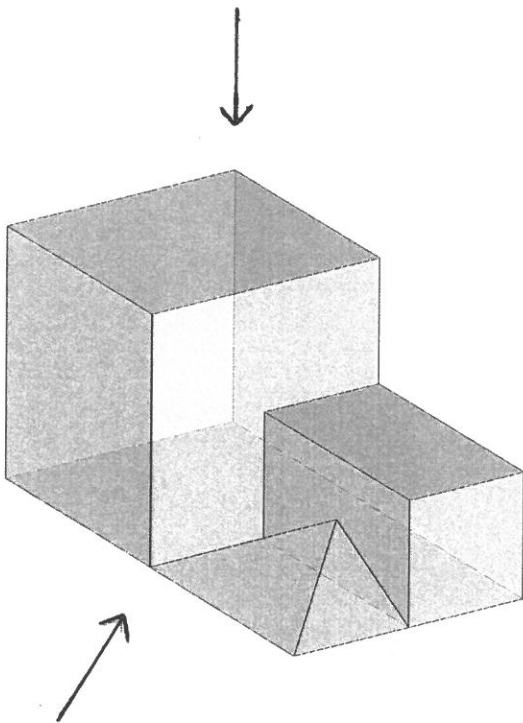

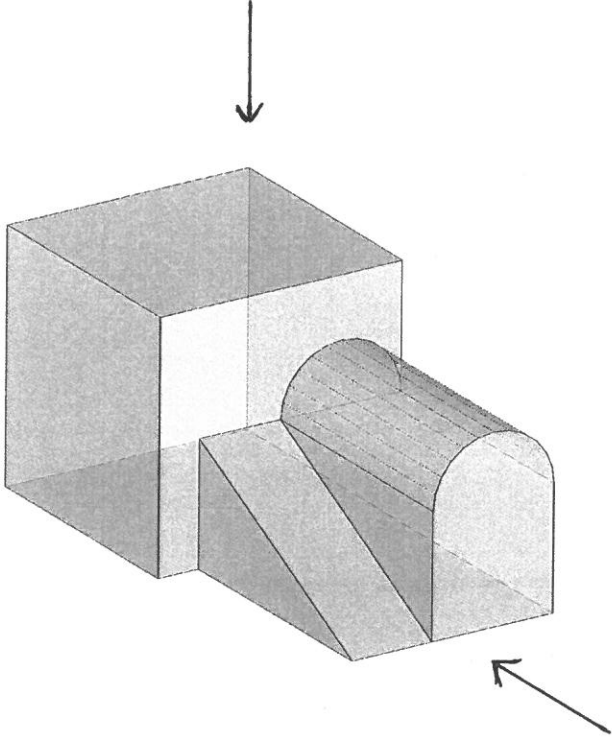
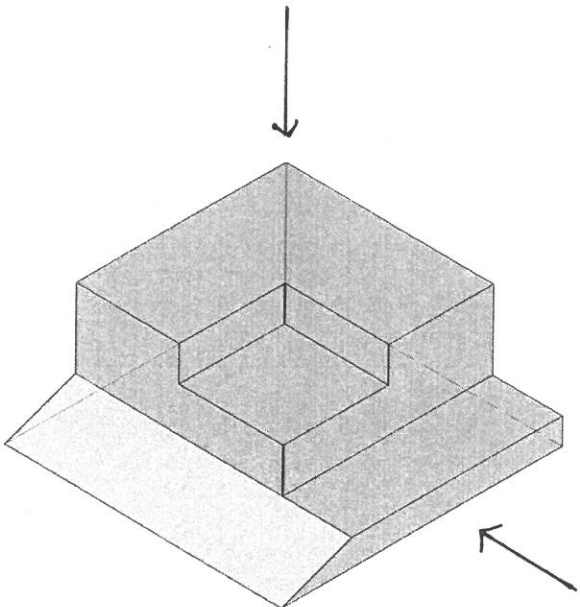
<p>Q10</p>		
<p>Q11.</p>		



Q12	Identify the logo of State bank of India		
<input type="radio"/>	A	<input type="radio"/>	B
<input type="radio"/>	C	<input type="radio"/>	D

Q13.	CMYK stand for		
<input type="radio"/>	Coronary Multiple Yield Ketosis	<input type="radio"/>	Crimson, Magenta, Yellow, Kala
<input type="radio"/>	Cyan, Magenta, Yellow, Key	<input type="radio"/>	Cartoon, Memory, Yielding, Knowledge

Q14.	Choose a letter that belongs to same font		
architecture			
1)a 2) a 3)a 4) a			
<input type="radio"/>	1	<input type="radio"/>	2
<input type="radio"/>	3	<input type="radio"/>	4

Q15.	Count the number of horizontal seen surfaces		
<input type="radio"/>	5	<input type="radio"/>	4
<input type="radio"/>	6	<input type="radio"/>	22



SECTION C (100 MARKS)

This section has 4 questions. Each question carries 25 marks.

- Q. 1 Render the given piece of furniture in any medium:**
Evaluation: Neatness, Colour Selection, Textures

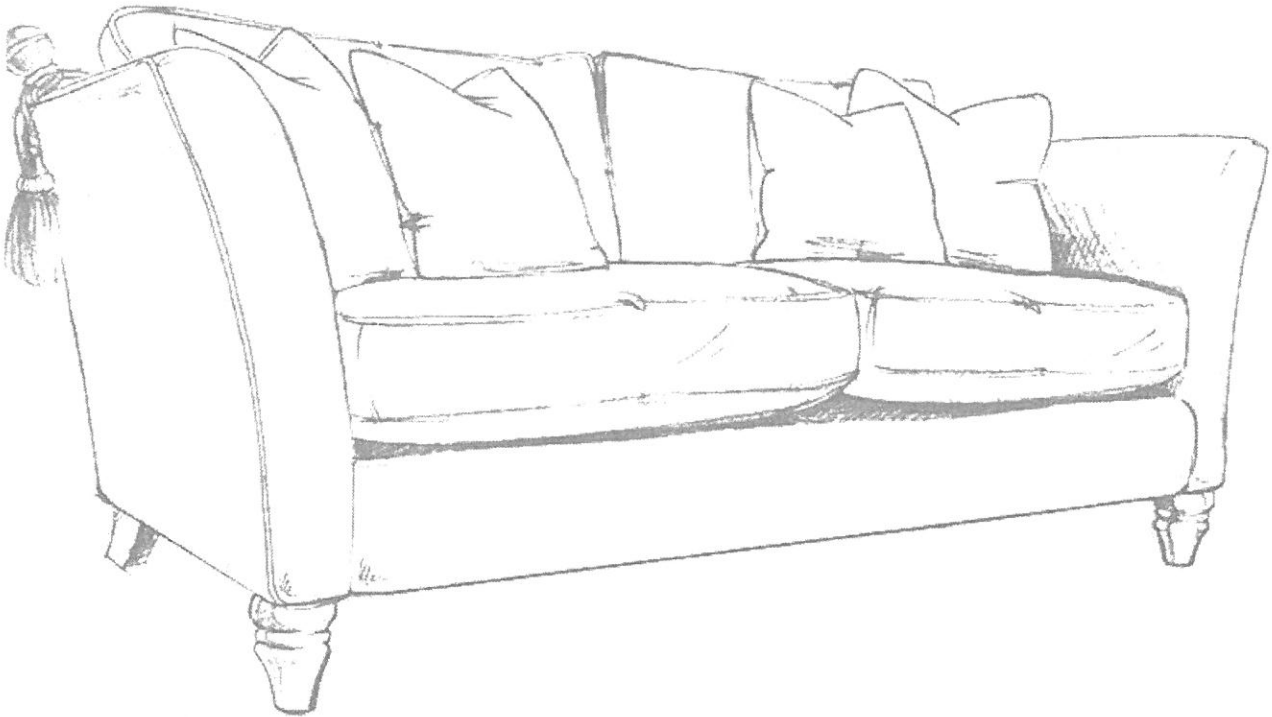



Q. 2 Render the following in appropriate colour scheme.





Q 3. Draw the shade and shadow of the given object. The Arrow shows the direction of Light

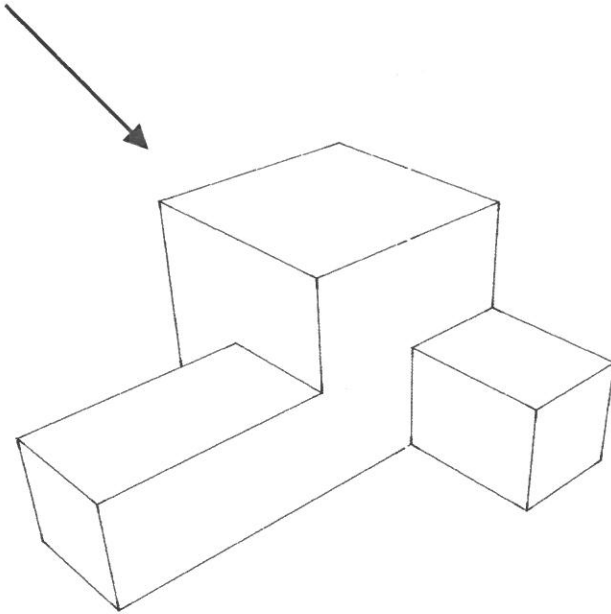



BOMBAY SUBURBAN ART AND CRAFT SOCIETY'S
L. S. RAHEJA SCHOOL OF ARCHITECTURE
(LACHMANDAS SEWARAM RAHEJA SCHOOL OF ARCHITECTURE)

B.VOC (INTERIOR DESIGN) APTITUDE TEST 2019 - 2020

- Q. 4 Draw any Artistic composition, by using following elements given below :
Squares, Straight Lines and Curve Lines. Render the Composition with pencil colours.

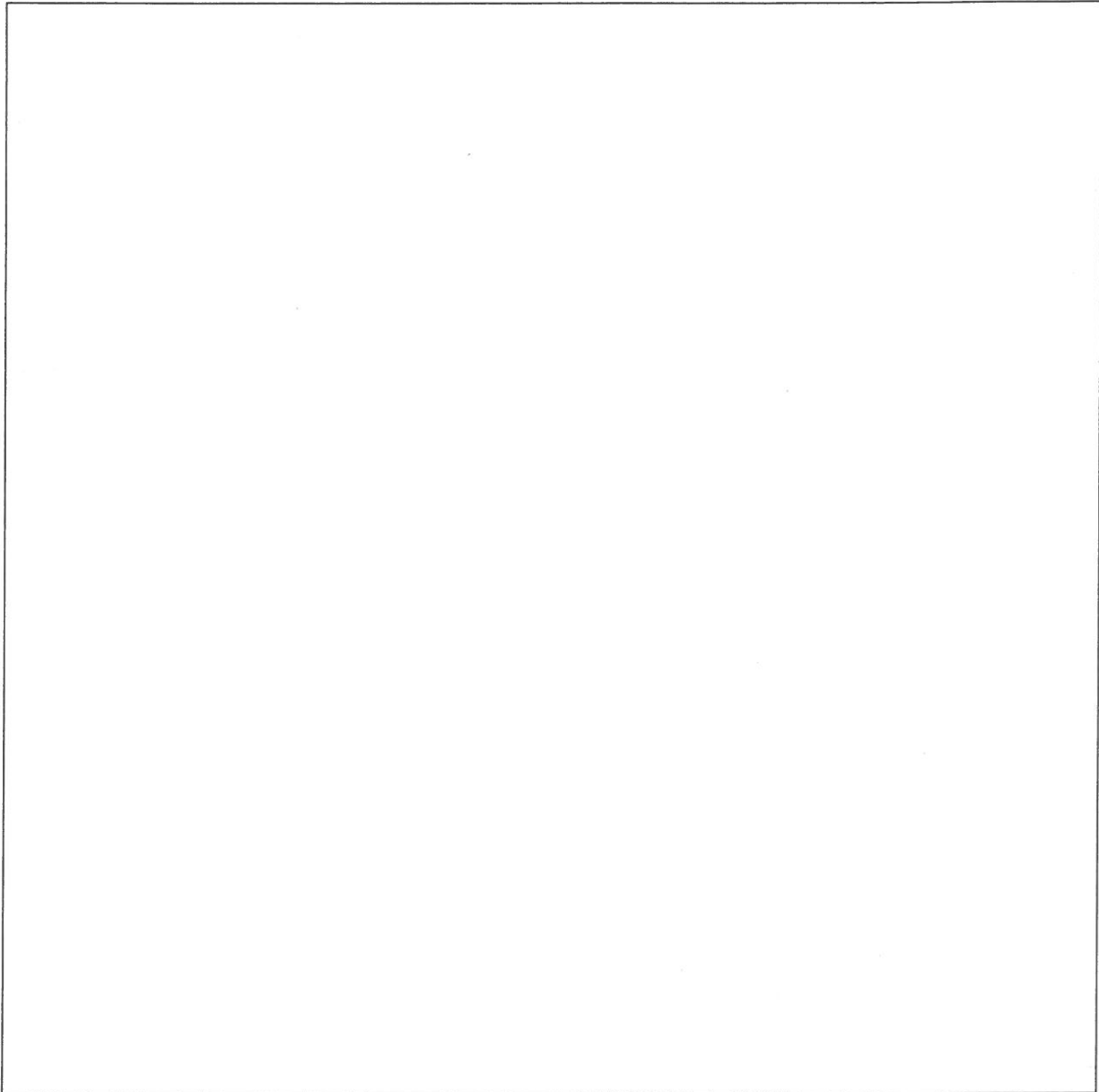



BOMBAY SUBURBAN ART AND CRAFT SOCIETY'S
L. S. RAHEJA SCHOOL OF ARCHITECTURE
(LACHMANDAS SEWARAM RAHEJA SCHOOL OF ARCHITECTURE)

B.VOC (INTERIOR DESIGN) APTITUDE TEST 2019 - 2020

ROUGH WORK SHEET



BOMBAY SUBURBAN ART AND CRAFT SOCIETY'S
L. S. RAHEJA SCHOOL OF ARCHITECTURE
(LACHMANDAS SEWARAM RAHEJA SCHOOL OF ARCHITECTURE)

B.VOC (INTERIOR DESIGN) APTITUDE TEST 2019 - 2020

ROUGH WORK SHEET